

REVISIONS				
REV	ECN NO.	CHANGE	DATE	APP'D
A	DFS ECO #1694	RELEASED TO PRODUCTION. MV	3-5-19	HH

- NOTES:
1. ROHS AND REACH COMPLIANCE. REFERENCE AMETEK ENVIRONMENTAL SPECIFICATION ES0010 FOR DETAILS.
  2. ALL INTAKE, EXHAUST, COOLING DUCTS AND VENTS MUST NOT BE OBSTRUCTED BY MOUNTING.
  3. MOTOR VENTILATION AIR TO BE FREE OF OILS AND OTHER FOREIGN PARTICLES (I.E. BREATHING QUALITY AIR). MOTOR TO BE MOUNTED SO THAT MOTOR VENTILATION AIR CANNOT RECIRCULATE.
  4. AMP MATE-N-LOK PLUG CONNECTOR, PN# 350809-1 USING UNIVERSAL MATE-N-LOK SOCKETS WITH 18 GA WIRE (TO BE SUPPLIED BY CUSTOMER) MATES WITH BLOWER CONNECTOR 640900-1.
  5. MOLEX CONNECTOR SERIES 41695, #09-50-8053, USING MOLEX CRIMP TERMINAL #08-52-0113 WITH 20GA. WIRE (TO BE SUPPLIED BY CUSTOMER) MATES WITH BLOWER CONNECTOR 26-60-7050P.
  6. HOLES INDICATED MAY CONTAIN FLASH.

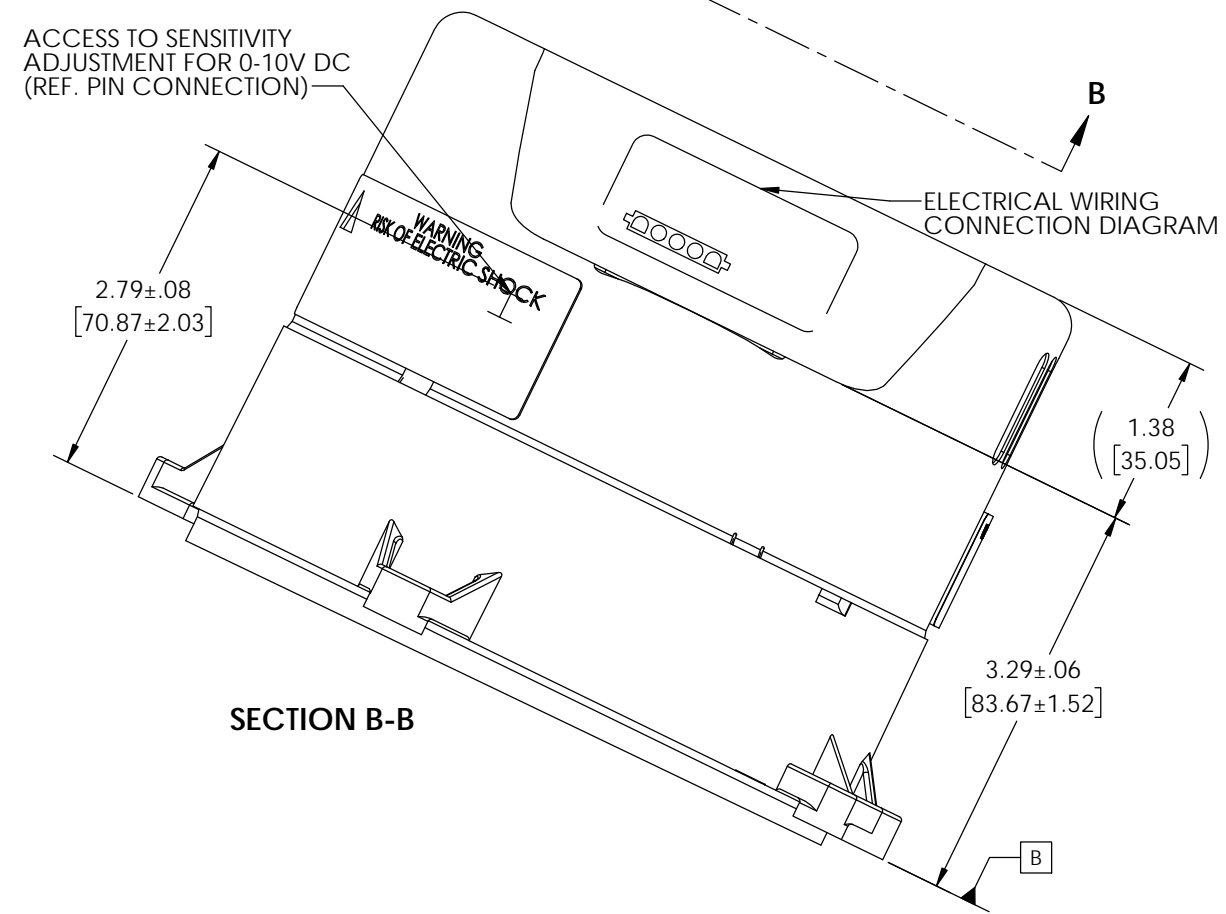
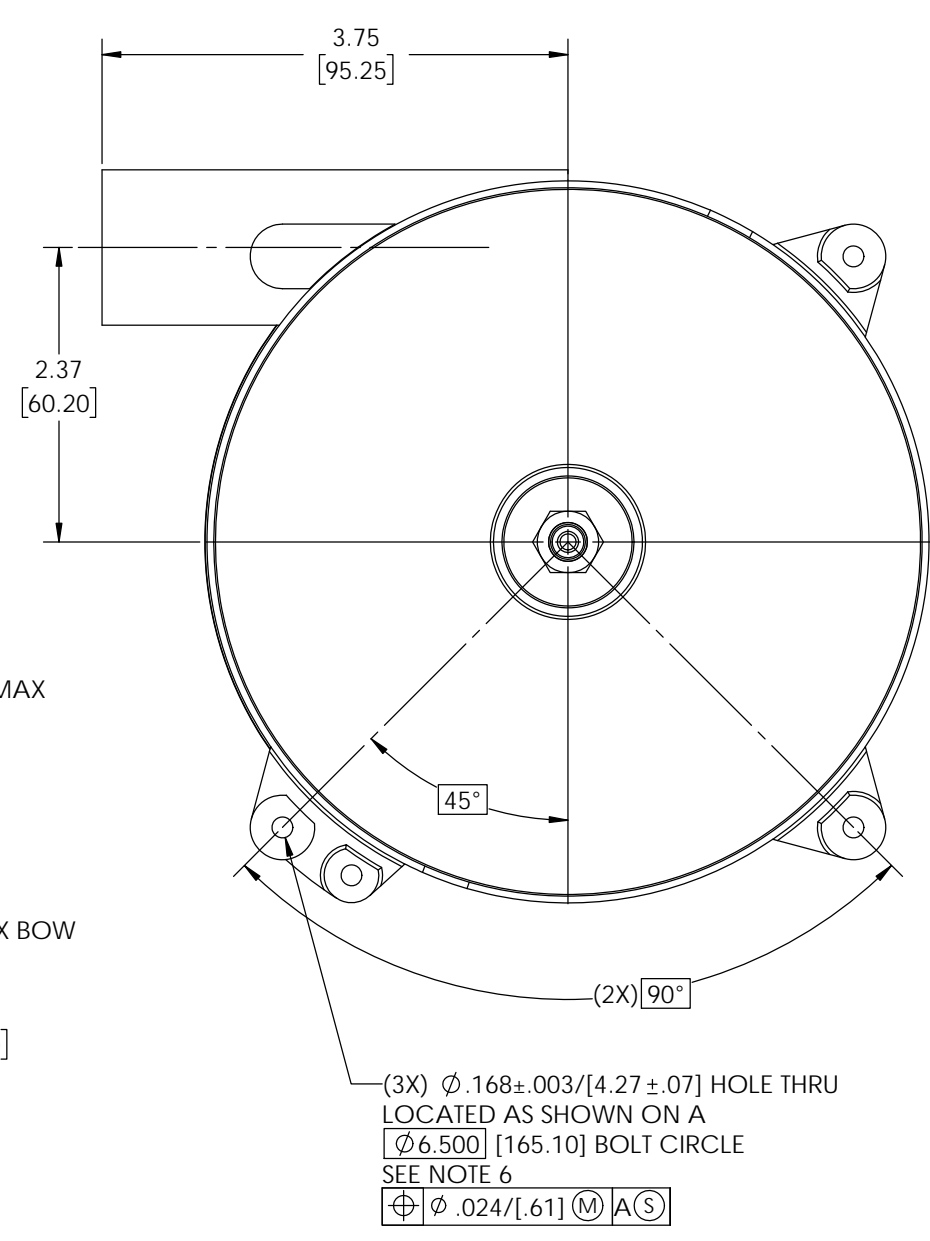
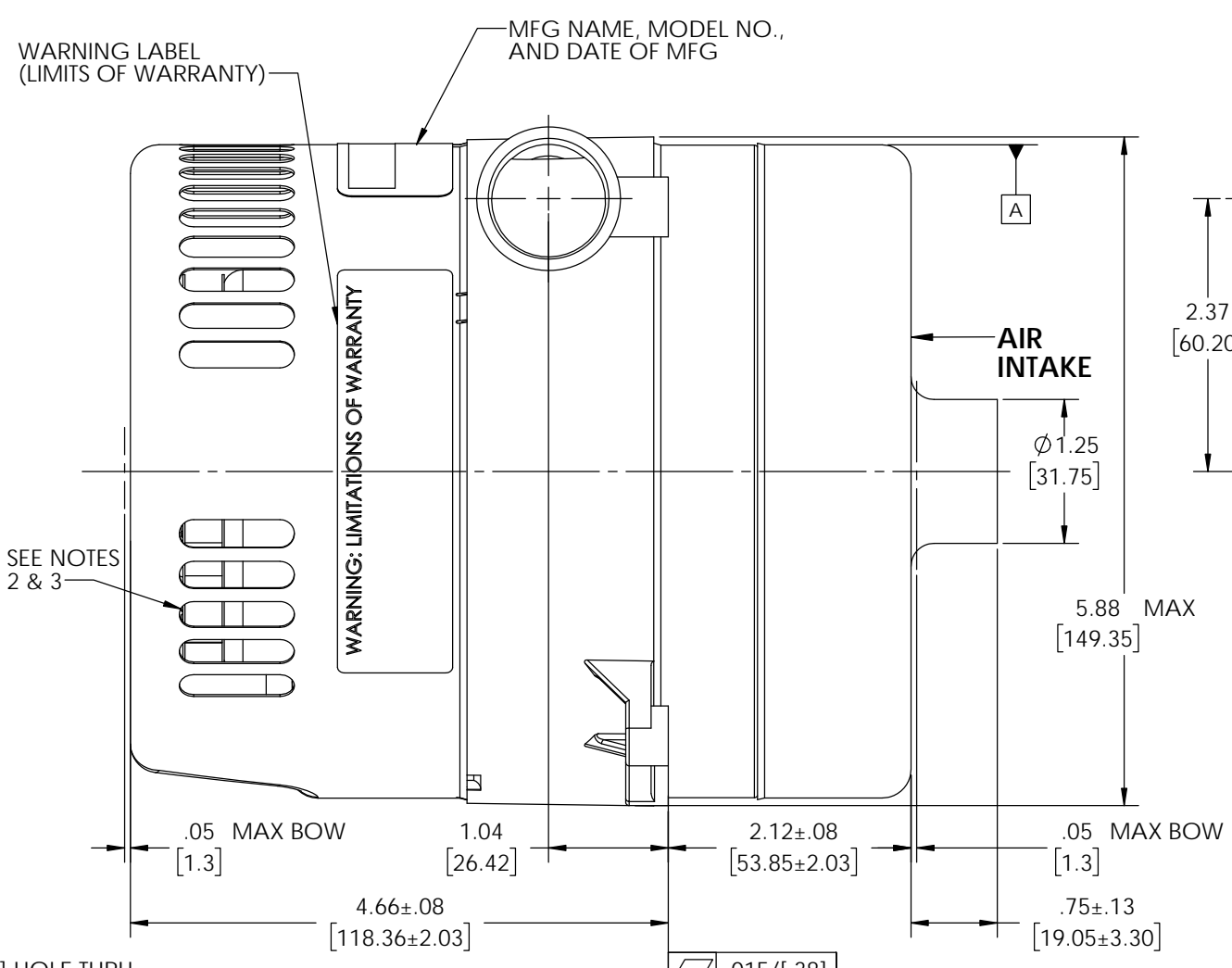
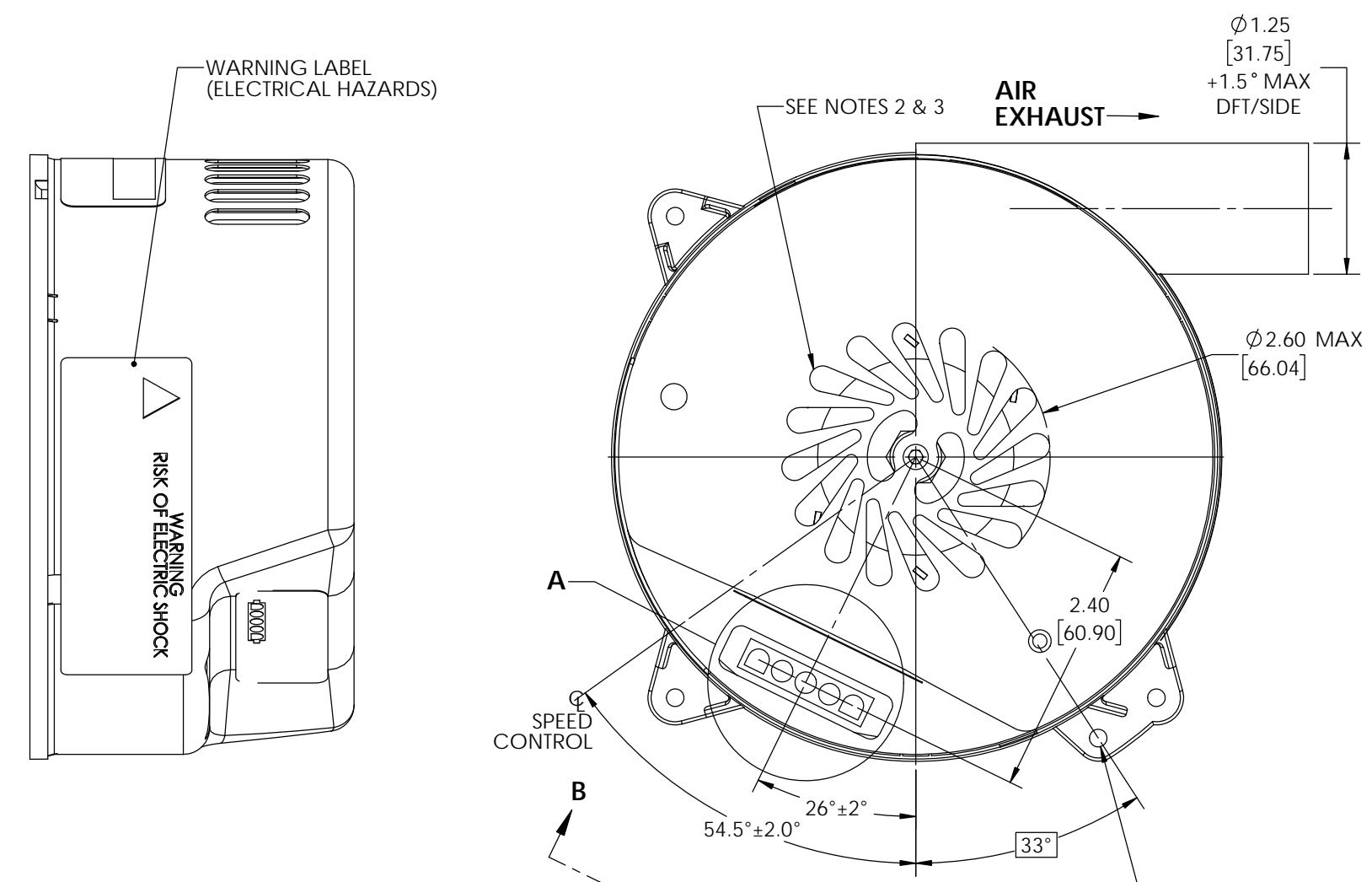

(1) Ø .168±.003/[4.27±.07] HOLE THRU LOCATED AS SHOWN ON A Ø 6.400 BOLT CIRCLE. [162.56]

USE THIS HOLE FOR GROUNDING OR EARTHING. REFER TO APPROPRIATE LISTING OR REGULATORY AGENCY FOR PROPER METHOD OF GROUNDING OR EARTHING. SEE NOTE 6

Ø .024/.61 (M) (A) (S)

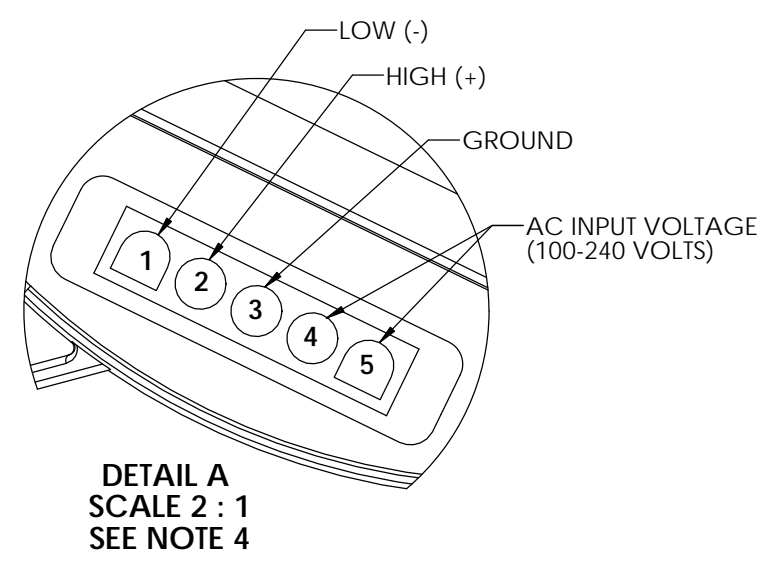

CONTROL CHARACTERISTICS M101-M199=MAJOR		REF. ENG. SPEC. K-1		SW
CONFIDENTIAL				
THIS PRINT AND THE SPECIFICATIONS ARE THE PROPERTY OF AMETEK, TECHNICAL & INDUSTRIAL PRODUCTS, AND HAS BEEN ISSUED WITH THE UNDERSTANDING THAT IT WILL NOT BE REPRODUCED, REVEALED TO OR USED FOR THE MANUFACTURE FOR OTHERS AND WILL BE RETURNED UPON REQUEST.				
DIMENSIONING AND TOLERANCING IN ACCORDANCE WITH ANSI Y14.5M-1982				
DO NOT SCALE DRAWING				
UNLESS OTHERWISE SPECIFIED		TOLERANCES		
REMOVE BURRS	XX	XXX	ANGLES	
BREAK SHARP EDGES .005/.020	±.02	.005	±0° 30'	
MATERIAL				
SCALE	1:1	CODE	75511	FINISH SPEC.
CAD FILE NAME	-	NEXT ASSY	-	WT.
ENG. APP'D:	G. BENNINGTON	DATE:	3-6-19	APP'D:
DRAWN BY:	M. VARGO	DATE:	3-5-19	CH'D BY:
TITLE				
5.7 100-240V, 600W BYPASS BRUSHLESS 3 STG UNIVERSAL BLOWER OUTLINE				
E-NO.				REF. 117417-51-0
DWG NO.				150366-73-0
AMETEK				SHEET 1 OF 1
DYNAMIC FLUID SOLUTIONS				