



LAMB ELECTRIC

Model: 119652-29

DESCRIPTION

- One stage Air Watt Series (AWS)
- 36 Volts
- 5.7"/145 mm diameter
- Double ball bearings
- Single speed
- Acustek Discharge
- Thermoset fan end bracket
- Thermoset Commutator bracket

DESIGN APPLICATION

- Equipment operating in environments requiring separation of working air from motor ventilating air
- Designed to handle clean, dry, filtered air only

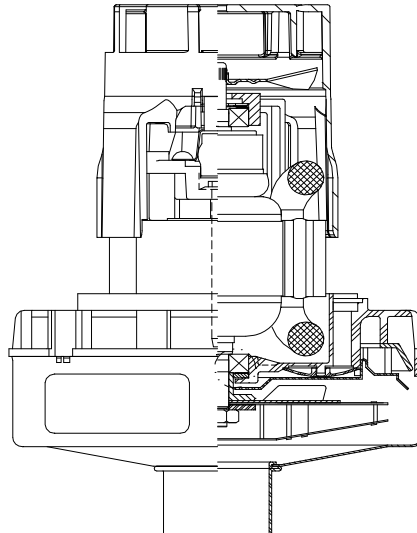

SPECIAL FEATURES

- Suitable for 36 volt DC operation
- UL Recognized, category PRGY2 (E47185)
- Provision for grounding
- Skeleton-frame design
- Epoxy painted fan case
- Patented air seal bearing construction. U.S. Patent #4,088,424
- Enhanced Air Seal
- The Lamb Electric vacuum motor line offers a wide range of performance levels to meet design needs.



TYPICAL MOTOR PERFORMANCE.*

(At 36 volts DC, test data is corrected to standard conditions of 29.92 Hg, 68° F.)

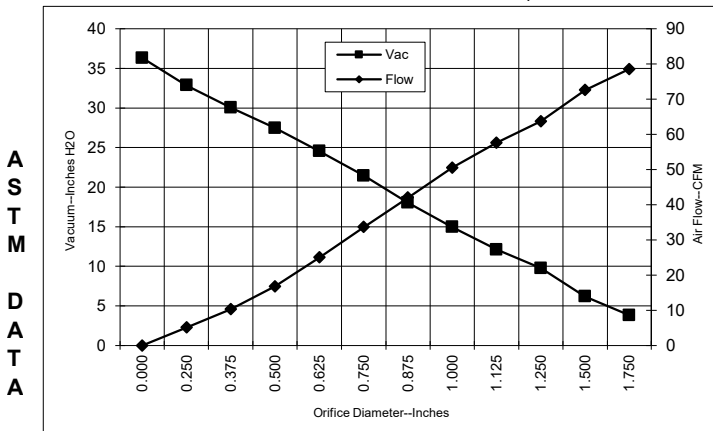

Orifice (Inches)	Amps	Watts (In)	RPM	Vac (In.H ₂ O)	Flow (CFM)	Air Watts
2.000	16.2	390	15780	2.5	82.5	24
1.750	16.2	389	15720	3.8	78.5	35
1.500	16.2	391	15650	6.2	72.6	53
1.250	16.1	387	15680	9.8	63.7	73
1.125	16.0	384	15830	12.1	57.6	82
1.000	15.7	378	16020	15.0	50.5	89
0.875	15.4	371	16260	18.0	42.0	89
0.750	15.0	361	16690	21.5	33.7	85
0.625	14.4	346	17210	24.5	25.0	72
0.500	13.7	328	17950	27.5	16.8	54
0.375	13.0	313	18630	30.1	10.3	36
0.250	12.4	299	19270	32.9	5.1	20
0.000	12.0	288	19900	36.3	0.0	0

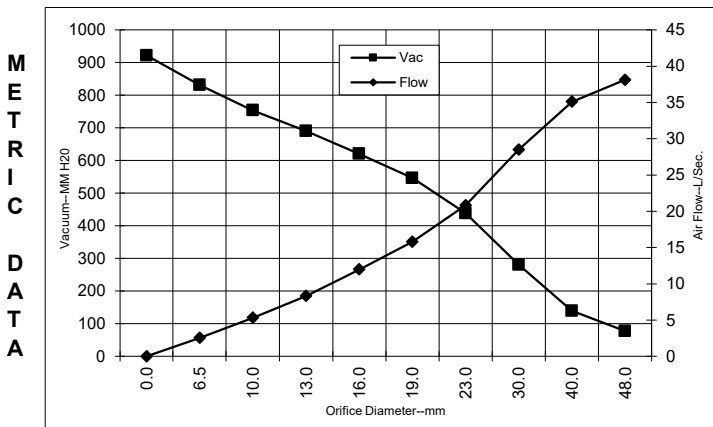

Orifice (mm)	Amps	Watts (In)	RPM	Vac (mm H ₂ O)	Flow (L/Sec)	Air Watts
48.0	16.2	390	15754	78	38.1	29
40.0	16.2	390	15671	139	35.1	48
30.0	16.1	385	15763	281	28.5	78
23.0	15.5	373	16200	439	20.8	89
19.0	15.0	361	16700	546	15.8	85
16.0	14.4	347	17189	620	12.0	73
13.0	13.7	330	17876	690	8.3	56
10.0	13.1	315	18528	754	5.3	39
6.5	12.5	300	19238	831	2.5	21
0.0	12.0	288	19900	922	0.0	0

Note: Metric performance data is calculated from the ASTM data above.

* Data represents performance of a typical motor sampled from a large production quantity. Individual motor data may vary due to normal manufacturing variations.

Test Specs:	36 volts	Minimum Sealed Vacuum:	40"	ORIFICE:	7/8 "	Minimum Vacuum:	17.0"	Maximum Watts:	600
--------------------	----------	-------------------------------	-----	-----------------	-------	------------------------	-------	-----------------------	-----

